

Application Failover Services

for Mission Critical Business Applications
[a discussion of options]

The information presented within is private and confidential to FUSION LABORATORIES INC. Unauthorized redistribution or use without prior authorization is strictly prohibited. © 2003 Fusion Laboratories Inc., Private and Confidential

Agenda

- **Intro to Fusion Labs**
- **Intro to the Application Lab**
- **What is Mission Critical**
- **Importance of Disaster Recovery**
- **Hot Sites and Warm Site**
- **The Fusion Approach to DR**
- **Sample Scenarios**
- **Value Summation**

What We Do

IT Consulting - fostering clients through the process of analysis, requirements gathering, development, implementation and adoption of technology solutions **helping to eliminate the guess work from complex initiatives**

IT Outsourcing - providing total end-to-end application support, unprecedented managed hosting, and business resumption services, **services that:**

- **scale to suit changing needs**
- **safeguard mission critical data**
- **assure security and optimize performance**

Solution Offering

- **Application Management**
 - **Application Implementation**
 - **Upgrades and Release Updates**
 - **Applications Sun-setting**
- **Application and System Hosting**
 - **24X7 Operational Support**
 - **Redundant High-Speed Network**
 - **Physical and Logical Security**
- **Infrastructure Management**
 - **Network Configuration and Administration**
 - **Desktop and Help Desk Environment**
 - **Security**
- **Application Commercialization**
 - **Product Development and Packaging**
 - **Marketing and Sales strategy**
 - **Commercial Hosting**
- **Critical Application Failover**
 - **3-tier Application Redundancy / Extension**
 - **2-tier Client/Server Redundancy / Extension**
 - **Remote Test and/or Development Environment**
- **Technology Envisioning**
 - **Senior Practice Area Specialist Roundtable**
 - **Product Evaluations**
 - **Project and Solution Development / Mentorship**
- **Security Services**
 - **Information Security Assessment**
 - **Network Security Architecture**
 - **Security Awareness and Training**
- **Financial Verification**
 - **IT Financial Reviews**
 - **Sarbanes-Oxley Compliancy Services**
 - **Financial Negotiation**

Skillset Inventory

Applications

- C++
- RPGIII
- PRGIV
- RPG400
- JavaPOS
- Pascal
- IBM Assembler
- IBM SPPS-2
- ZIM DBMS
- RedBack Server
- Oracle
- MS SQL
- DB2
- Unidata
- XML
- WebSphere

Databases

- DB2
- Oracle
- MS/SQL
- Sybase
- Teradata

Operating Systems

- Linux
- HP UNIX
- Sun UNIX
- DOS
- OS2
- SCO UNIX
- AIX
- ATT UNIX
- OS400
- TSO/ISPF
- IMS/VS
- QMF
- MVS
- DOS/VSE
- VM DATACOM/DB
- DB2
- CICS,
- Microstrategy DSS
- PL/SQL, SQL
- IDEAL
- COBOL
- DMS
- RACF

Hardware

- AS400
- System 34,36,38
- Telephony, ACD, IVR, PBX, Voiceover IP
- Mitel, ROLM
- Northern Telecom
- Telrad, Octel IVR
- Symbol Technologies
- Norstar, Octel, Startalk, VX2
- Executone, Siemens
- Mitel
- Telxon handheld
- Amdahl / IBM mainframe
- IBM mainframe,
- RS/6000

Point of Sale Systems

- POS systems design
- Direct Store Delivery
- IBM POS 3660 3680 4680 4690
- NCR POS 3550
- ICL POS sw/18, ISS 400
- CRS POS software
- STR POS software
- IBM GSA
- OMRON POS

Package Applications

- Lawson
- MAPICS
- Novell Groupwise
- Lotus Notes
- Softechnics Chaintrack
- JDA DCMS, MMS, financials
- Oracle Financials
- PeopleSoft
- Arthur Planning
- EXE (Dallas Systems)
- Syncra – CPFR
- JDE
- Manugistics
- SAP
- Logility
- Uniteq Warehouse System
- Tomax (Retail.net)
- GEAC Manufacturing
- ReTek
- EDX/EDI

Application Lab Details

Security

- 24x7x365 Controlled Building Access
- Card Access Entry Systems
- Site Video Surveillance
- 24hour CCTV Security Monitors

Power Capabilities

- 480 volt 3 phase power
- 240 / 208 / 120VAC
- 4800ah – 48v DC
- AC/DC power for all equipment types

Connectivity

- Redundant, fast Ethernet
- Tier-One Access to Multiple Carriers
- Scalable bandwidth (1Mbps/OC-48)
- T1, OC-3, OC3c, DS3, Fractional DS3

Redundant Power Systems

- 3 phase 350 kVa Diesel Generator
- Battery Back-Up
- Uninterruptible Power Supply (UPS)
- Automatic Transfer Switches (ATS)

Conditioned Environment

- Independent HVAC
- 72-degree air temp 45% humidity
- Supplemental HVAC
- 1300 tons of cooling available

Fire Suppression Systems

- Dry Pipe Suppression Systems
- Zone Specific Discharge
- Smoke Detection Systems
- Heat Detection Systems

Mission Critical Business Applications

Definition:

Services and activities whose continued operations is considered essential for operation of the firm. Each of these applications has a specific “must recover” time frame.

For many companies the mission critical applications are ERP/CRM, applications, eCommerce, Supply Chain or business specific legacy systems. Increasingly these mission critical applications have become web enabled by intent or design.

Disaster Recovery & Business Continuity

- Should a disaster occur, mission critical applications must recover quickly
 - 42.% of applications < 1 day *
 - 37% of applications < 1-2 days *
 - In some cases financial applications must recover in < 12 hours
- Planning for the entire spectrum of Business Continuity and Disaster Recovery scenarios has taken on new importance after 9/11 and as a result of new SEC regulations.
- The continuing pressure on IT budgets has created ongoing challenges. 70% of businesses report Funding and Staff Shortages as fundamental challenges to disaster recovery planning*

* Disaster Recovery Journal

Typical Recovery Techniques

- Businesses typically use one of two approaches for recovering mission critical applications:
 - Hot Site
 - Warm Site
- Both are effective but both have issues
 - Cost
 - Timeliness/Availability
 - Dependency on execution of “one off” processes that are only practiced once or twice a year.

Hot Site

An alternate facility that already has in place the computer, telecommunications, network and infrastructure necessary to recover an application(s)

- This approach is used by 2/3 of businesses for recovery of mission critical applications
- Executing this approach requires significant investment in unique processes, documentation, and technology
 - Nearly 60% of business are Not Confident or Somewhat Confident the solution will work when needed*
 - Most companies only test their procedures once or twice a year

* Disaster Recovery Journal

Warm Site

An alternate facility that already has the environmental infrastructure, pre-configured computing equipment, and network access available on a shared basis. The computer equipment is not pre-loaded with software nor is the latest data available. These must be installed prior to use.

- Lower cost than Hot Site
- Executing this approach also requires significant investment in unique processes, documentation, and technology
- Implementing a Warm Site often requires 3 or more days
 - Most mission critical applications must be operational < 2 days
- Reliability of execution is problematic
 - Testing of the solution is difficult and is usually only done once a year

Fusion Labs Differentiation

- **Leverage customer's existing assets**
- **Leverage 3-tier architectural capability**
- **Leverage existing software licenses**
- **Leverage enterprise class application operational designs**
- **Leverage off the shelf network capabilities**
- **Significantly change customer economics**
- **Significantly change execution reliability**

Leverage 3 tier Architecture

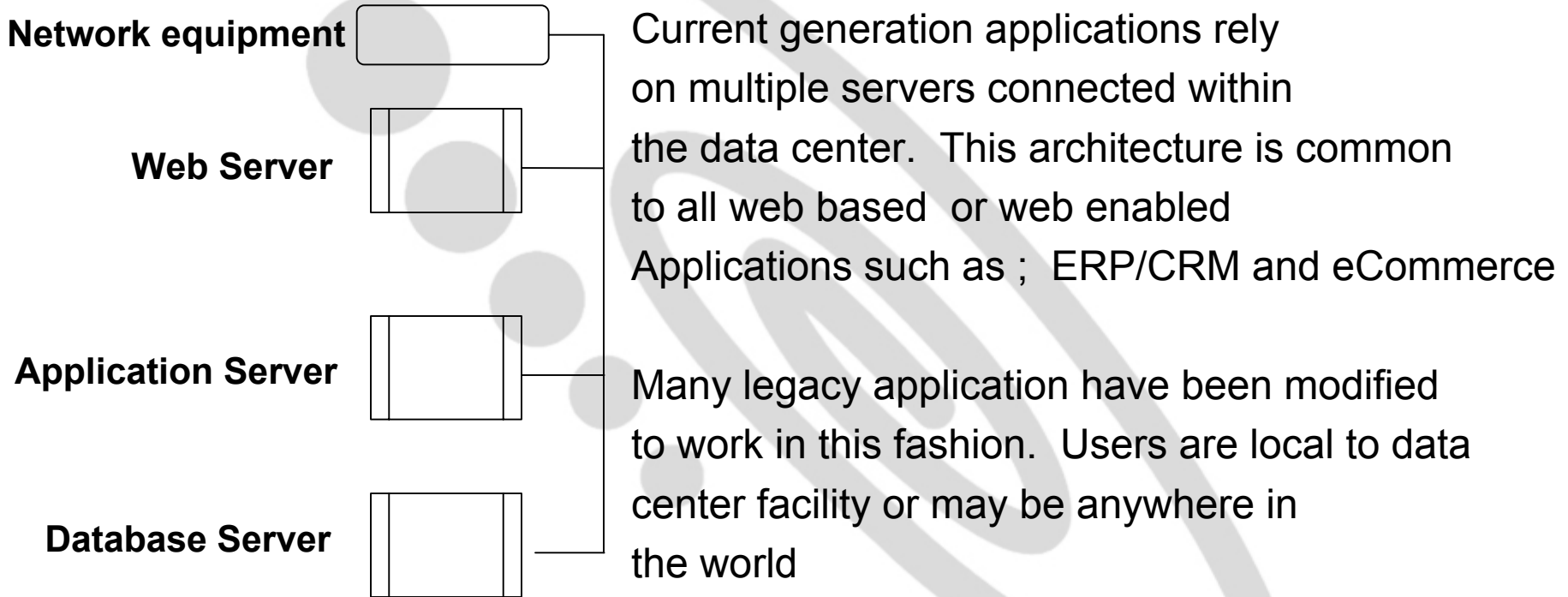

Leverage Enterprise Operational Designs

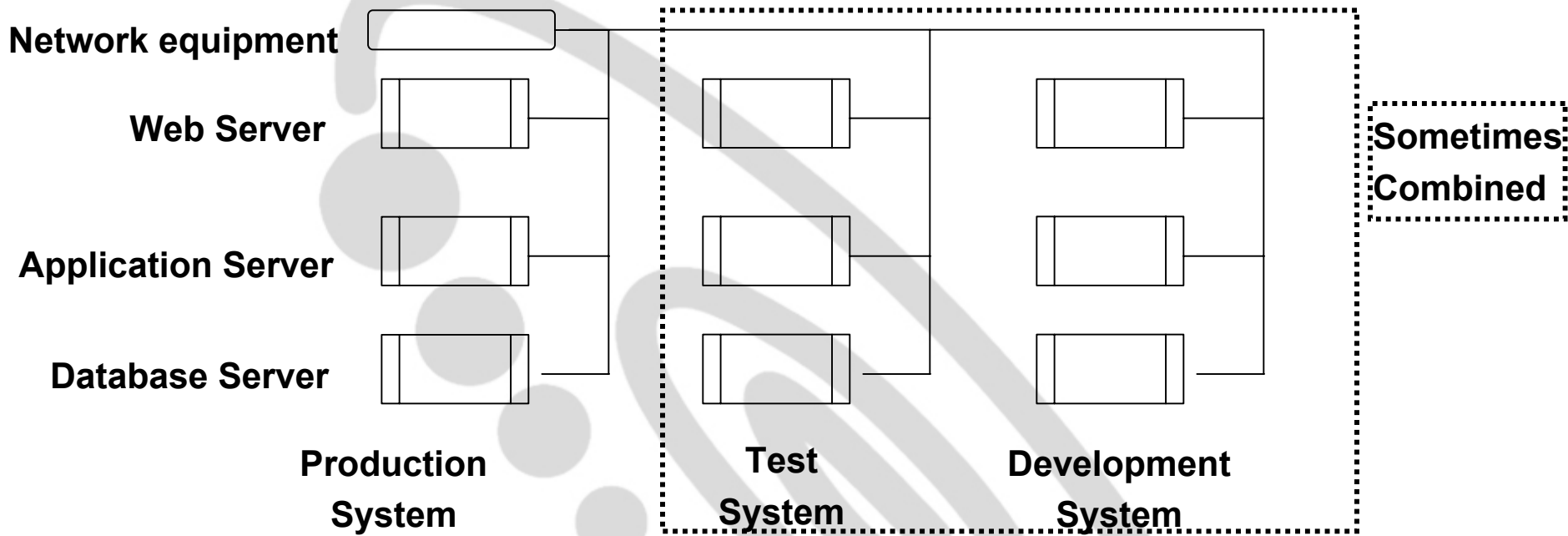

- Routine practices involve replicating the Production configuration in a Test and/or combined Test/Development environment
- Test/Development systems are often used for local failover in the event of a problem in the Production environment.

The Fusion Solution

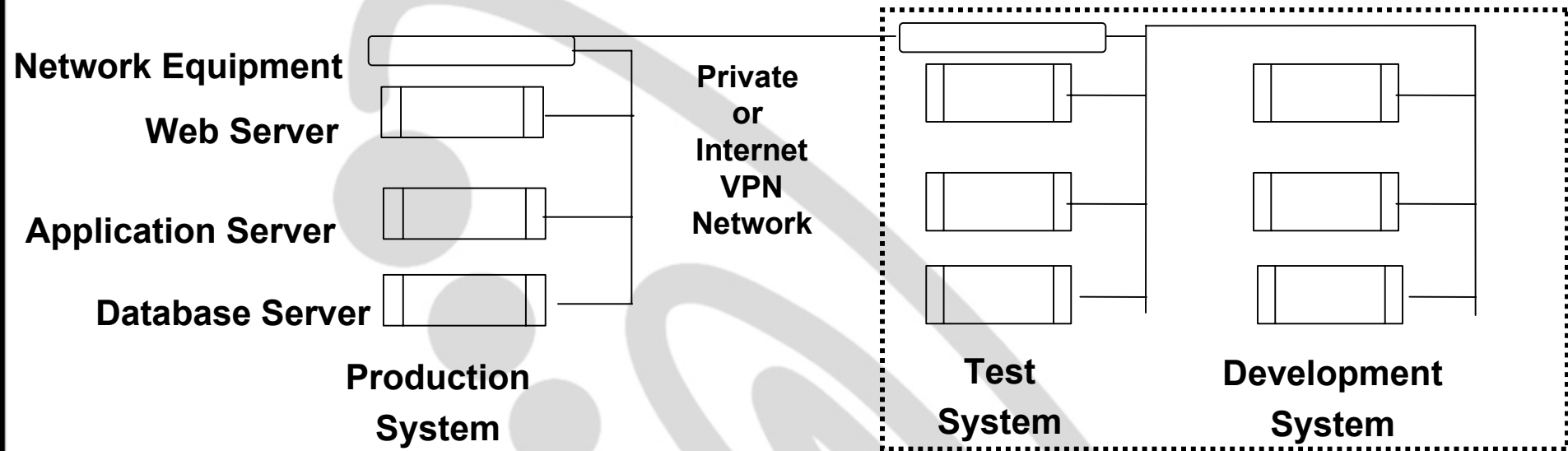

- Relocate the Test and/or Development system to the Fusion Labs Data Center
- Provide an appropriate network connection(s)
- Extend operational management to include the remotely attached system
- Add procedures to remotely invoke a “fail over” event or have Fusion Labs execute the process

A Representative Example

Peoplesoft Example:

- The client utilizes a development environment in addition to production which is configured to provide “fail over”
- The Development environment resides at the Fusion Labs data center as an “extension” of the clients network and data center operations.
- The client uses existing management and operational processes, procedures, and tools; Fusion Labs provides minimum technical support for back-up and local console events.
- Shifting to “fail over” or disaster back up mode requires minimal time and uses standard client change management documentation.

Economic Comparisons

Description	Hot Site	Warm Site *	Fusion Service
Hardware	\$ 3,304	\$ 1,652	n/a
Software License	\$ 3,463	\$ 3,463	n/a
Data center Space	\$ 1,250	\$ 625	\$ 1,250
Technical Services	\$ 1,875	\$ 1,875	\$ 1,875
Bandwidth	\$ 1,700	\$ 1,700	\$ 1,700
Monthly Total	\$ 11,592	\$ 9,315	\$ 4,825
36 month total	\$ 417,304	\$ 335,335	\$ 173,700
Potential Savings with Fusion Solution	\$ 243,604	\$ 161,635	
*Note: Does not include the additional cost of PeopleSoft Licenses and Utilities for the hot or warm sites.			

The example above is a mid-size PeopleSoft system with Financials and HR
 The Hot and Warm Site examples do not include any additional PeopleSoft Licenses
 *The Warm Site economics are shown for reference but are not applicable as the recovery time is too long

Functional Comparisons

- Hot & Warm sites rely on “one off” processes
 - Employee training is an ongoing issue
 - Infrequent testing implies lower reliability
- Hot sites must continually be kept in synch with the Production environment
- Warm sites require periodic renegotiation as equipment configurations change
- Fusion Labs solutions uses standard operational procedures, existing processes, existing equipment, and continuous operation

Bottom Line

- The Fusion Labs solution is dramatically more cost effective and reliable than a Hot Site recovery scenario.
- Economic investment is minimized, recovery speed is maximized, and unique processes are virtually eliminated.
- Any multi-tier application is a candidate!